

DATA SHEET

12 V 300 Ah



GENERAL SPECIFICATIONS

Model	GT12V300-LTCAN-A20
Chemistry	LiFePO4
Nominal Voltage	12.8 V
Nominal Capacity	300 Ah
Nominal Energy	3840Wh
Cycle Life	> 2000 cycles @ 100% DOD

MECHANICAL SPECIFICATIONS

Dimensions (L x W x H)	20.6 in x 10.55 in x 8.8 in
Weight	88.18 lb
Casing Material	ABS, UL-94 V-0
Terminal Type	M8
Enclosure Protection	IP56

TEMPERATURE SPECIFICATIONS

Charge Temperature	-30 °C to 45 °C (-22 °F to 113 °F)
Discharge Temperature	-40 °C to 60 °C (-40 °F to 140 °F)
Storage Temperature	-40 °C to 60 °C (-40 °F to 140 °F)
BMS High Temperature Cutoff	80 °C (176 °F)

OTHER SPECIFICATIONS

Self-Discharge	2% per month
Parallel/Series Connection	4 Parallel / No Series
Efficiency	99%
Resistance	$\leq 30 \text{ m}\Omega$

Manufactured and distributed by Grand Teton Energy Systems.

Performance may vary depending on application. All specifications and operating conditions are subject to change without notice. This data is provided for evaluation purposes only and does not imply any warranty or guarantee. Grand Teton Energy Systems. All rights reserved.

Version 005 - Revised 03-26-2026

CHARGE SPECIFICATIONS

Charge Voltage	14.4 V to 14.8 V
Charge Method	CC-CV
Recommended Charge Current	100 A
Maximum Charge Current	200 A
BMS Charge Cutoff Voltage	15.6 V
Recommended Float Voltage	13.8 V

DISCHARGE SPECIFICATIONS

Continuous Discharge Current	200 A
BMS Discharge Cutoff Voltage	10 V
Reconnect Voltage	11.2 V
Pulse Discharge Current	600 A (< 3 seconds)
Recommended Voltage Disconnect	10 V
Short Circuit Protection	200 to 600 μs

COMPLIANCE SPECIFICATIONS

Certifications	CE UL 1642 (Cell) IEC62133 & CB KC BIS
Shipping Classification	UN3480 Class 9 UN38.3

BATTERY RECYCLE

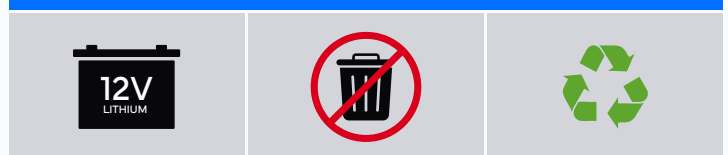

NOTE: Do not mix with sealed lead-acid batteries when recycling. Refer to the Grand Teton user manual for proper operation.

BATTERY DIMENSIONS

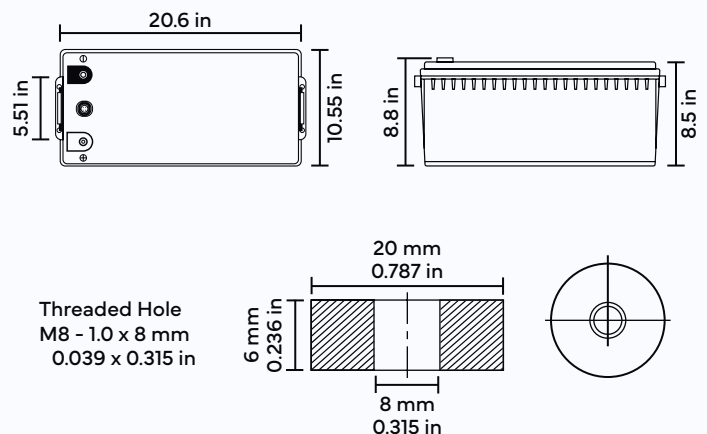

DATA SHEET

12 V 300 Ah



BATTERY APPLICATIONS

- ⚡ Data Center UPS
- ⚡ Telecom Backup Power
- ⚡ Military Power Supply
- ⚡ Solar Energy Storage Systems
- ⚡ Solar Street LED Lighting
- ⚡ Autonomously Guided Vehicles (AGVs)
- ⚡ Industrial Robotics & Handling Equipment
- ⚡ Aerial Work Platforms
- ⚡ Floor Cleaning Machines
- ⚡ Power Tools & Lawn Mowers
- ⚡ Electric Bikes & Motorcycles
- ⚡ Electric Mobility Devices (E-scooters, Wheelchairs)
- ⚡ Golf Trolleys & Golf Carts
- ⚡ Medical Devices
- ⚡ Electric Ships
- ⚡ Passenger Vehicles



PERFORMANCE CHARACTERISTICS

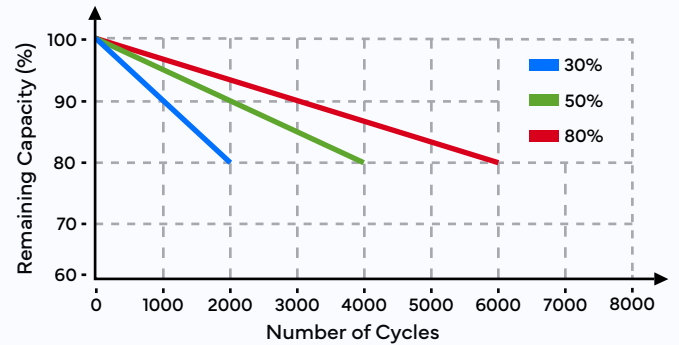

Cycle Life vs. Depth of Discharge (DOD)
Discharge @ 0.5C, 25 °C

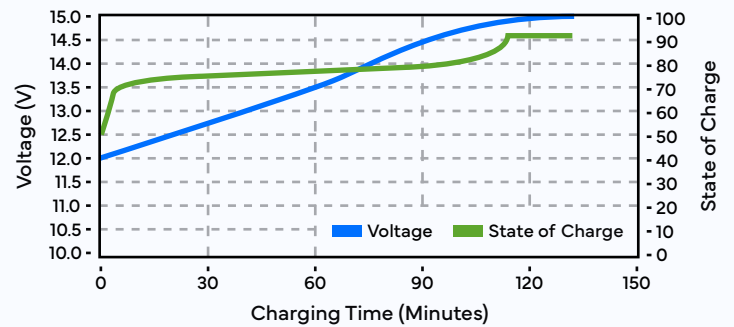

State of Charge Curve @ 0.5C, 25 °C

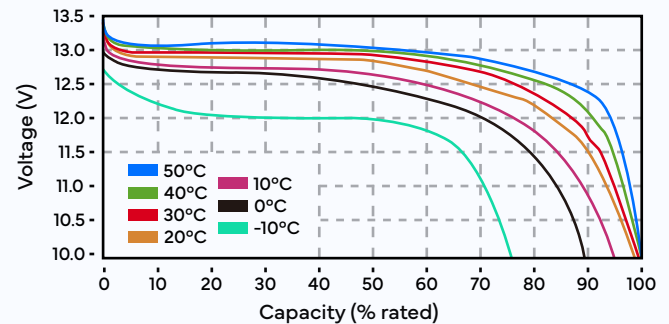

Discharge Capacity at Various Temperatures
Discharge @ 0.5C, 25 °C

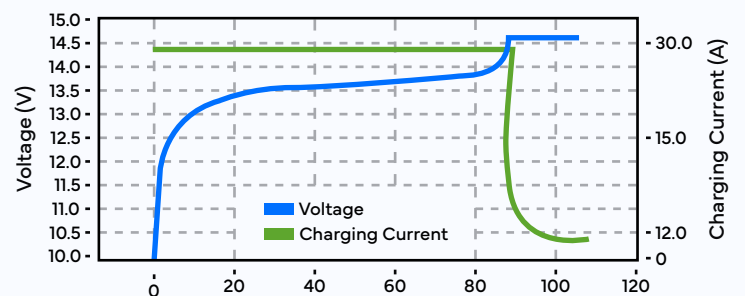

Charging Characteristics @ 0.5C, 25 °C